

Form
CS

BALL JOINTS

DIN 71802 form CS



Dimensions mm

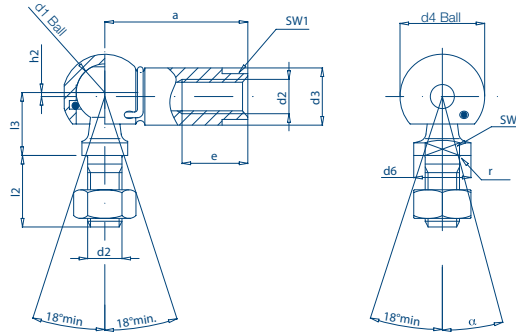

DESIGNATION	d1	d2 6g/6H**	a ±0,3	d3 ±0,5	d4 ±0,5	d6 h14	e min.	h2 ±0,5	l2 ±0,3	l3 ±0,3	r max.	*sw h14	*sw1 h14	α° ≈	weight ≈ (kg)
CS 8 M5	8	M5	22	8	12,8	8	10,2	0,65	10,2	9	0,3	7	7	10	0,015
CS10 M6	10	M6	25	10	14,8	10	11,5	0,7	12,5	11	0,3	8	8	15	0,025
CS13 M8	13	M8	30	13	19,3	13	14	1,15	16,5	13	0,5	11	11	15	0,053
CS16 M10	16	M10	35	16	24	16	15,5	1,15	20	16	0,5	13	13	15	0,104
CS16 M12	16	M12	35	16	24	16	15,5	1,15	20	16	0,5	13	-	15	0,150
CS19 M14x1,5	19	M14x1,5	45	22	30	19	21,5	0,5	28	20	0,8	16	-	15	0,221
CS19 M14x2	19	M14	45	22	30	19	21,5	0,5	28	20	0,8	16	-	15	0,221
CS19 M16	19	M16	45	22	30	19	21,5	0,5	28	20	0,8	16	-	15	0,221

*spanner flats
**tolerances d2: ball stud 6g-threaded hole 6H

Form
C

DIN 71802 form C



Dimensions mm

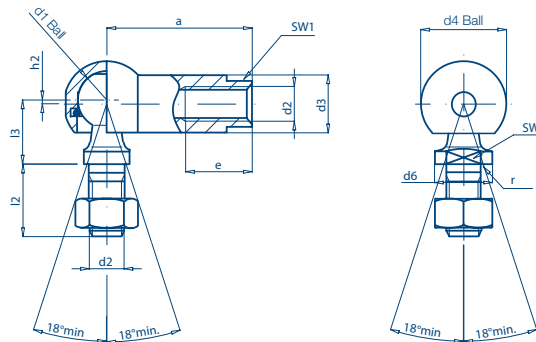

DESIGNATION	d1	d2 6g/6H**	a ±0,3	d3 ±0,5	d4 ±0,5	d6 h14	e min.	h2 ±0,5	l2 ±0,3	l3 ±0,3	r max.	*sw h14	*sw1 h14	weight ≈ (kg)
C 8 M5	8	M5	22	8	12,8	8	10,2	0,65	10,2	9	0,3	7	7	0,015
C10 M6	10	M6	25	10	14,8	10	11,5	0,7	12,5	11	0,3	8	8	0,025
C13 M8	13	M8	30	13	19,3	13	14	1,15	16,5	13	0,5	11	11	0,053
C16 M10	16	M10	35	16	24	16	15,5	1,15	20	16	0,5	13	13	0,104
C16 M12	16	M12	35	16	24	16	15,5	1,15	20	16	0,5	13	-	0,150
C19 M14x1,5	19	M14x1,5	45	22	30	19	21,5	0,5	28	20	0,8	16	-	0,221
C19 M14x2	19	M14	45	22	30	19	21,5	0,5	28	20	0,8	16	-	0,221
C19 M16	19	M16	45	22	30	19	21,5	0,5	28	20	0,8	16	-	0,221

*spanner flats
**tolerances d2: ball stud 6g-threaded hole 6H

For left-hand thread add "LH" (ex. CS 16 M10 LH o C13 M8 LH)

Technical reading from page 68 to page 69

MATERIALS

Ball stud: carbon steel with 60 daN/mm² resistance to tensile stress and inner ring hardened on the surface with a ≥ 52 HRC hardness

Ball socket: steel 11SMnPb30 with a 50 daN/mm² resistance to tensile stress (1.0718)

Internal snap ring "R": steel for springs C98 UNI EN 10270-1 DH

Safety clip "S": steel for springs C98 UNI EN 10270-1 DH

Surface protection:

- Zinc plating according to EN ISO 4042, Fe/Zn 8c...
- Chromate treatment (passivation) example: type A please add 1A (ex.:CS 10 M6 1A)
- Surface treatment table at page 6

Tolerances:

The dimensional tolerances shown in the table make reference to zinc plated products.